

Technical Information.



accurate and reliable level measuring regardless of the product reflection power.

Main specifications.

Measuring range.....	0.6 – 30m
Maximum absolute error.....	±3mm
Measuring beam width	15°
Connection	flanged
Ambient temperature.....	-50 .. +50 °C
Electrical connection	4-wire
Digital interface.....	.RS485 (Modbus RTU)
Analog interface.....	4-20mA/HART
Supply voltage	20-36VDC
Embodiment	explosion-proof 1ExdIIBT6
Weight	not more than 8kg

Intended application.

ULM-11A1 radar level transmitter is designed for reliable noncontact level measuring of liquids or granular materials. It is used to measure a level of both neutral and aggressive products. The level transmitter doesn't contact with the measured product and is equipped with a protected heated antenna. It is the best solution for technological accounting systems and measuring under severe conditions, when the low price is important.

Advantages.

- Absence of contact with the product – level transmitter is a maintenance-free device
- High measuring accuracy
- Protected heated antenna ensures effective protection against condensate formation
- Absence of additional temperature error.

Operating principle.

The level transmitter emits a continuous frequency-modulated electromagnetic microwave to the measured product. The reflected wave returns to the level transmitter antenna, where it combines with the emitted wave. The separated resultant frequency corresponds to a distance to the measured product. The measured distance is subtracted from the mounting height, thus a tank filling level is determined. Guaranteed precise separation of the resultant frequency by means of special algorithms ensures

Housing.

The housing is made of anodized aluminum with powder coating. It provides explosion protection as an explosion-proof casing. 1ExdIIBT6 explosion protection marking. IP65 dust and moisture ingress protection rating.

Materials.

The level transmitter parts contacting with the tank interior content are made of PTFE and stainless steel.

Embodiment options.

As an option, ULM-11A1 level transmitter can have an embodiment suitable for low temperature applications from -60 °C.

Electrical connections.

The design of ULM level transmitters makes it possible to simultaneously use digital RS485 and analog 4-20mA interfaces. Both interfaces can be used simultaneously and independently.

ULM-11A1 level transmitter (ULM4.01.000-01-M level sensor order code). Overall dimensions.

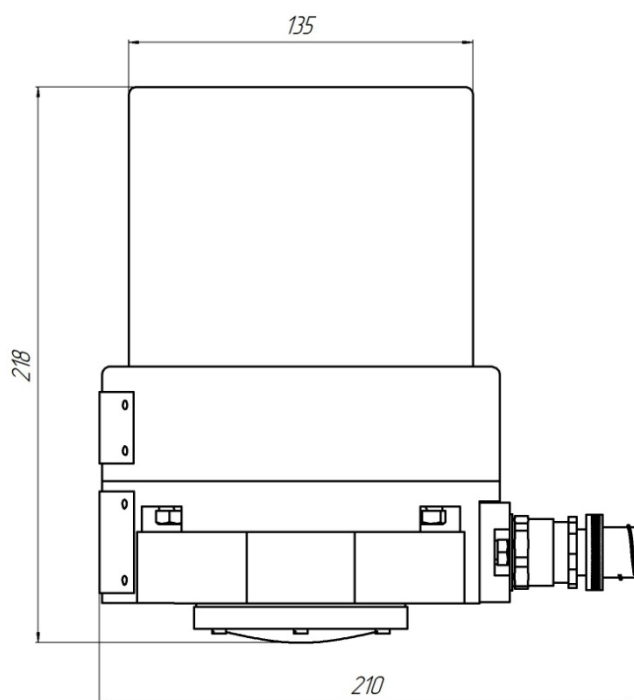

ULM-11A1 level transmitter installation with an insulating radiotransparent gasket.

This installation method is used to measure a level of aggressive and overheated products and makes it possible to completely isolate the tank interior content from the level transmitter and environment.

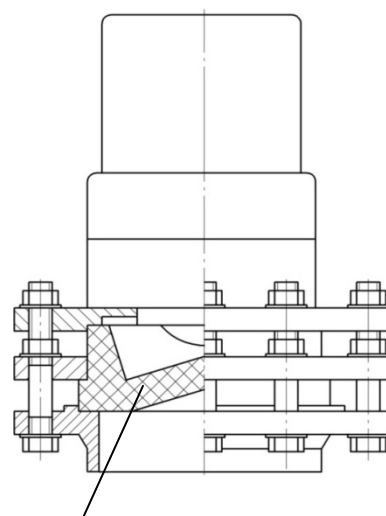

Insulating gasket (PTFE, ceramics)

Mounting (adapter) flange of ULM-11A1 level transmitter. Mounting dimensions in accordance with GOST 12821-80.

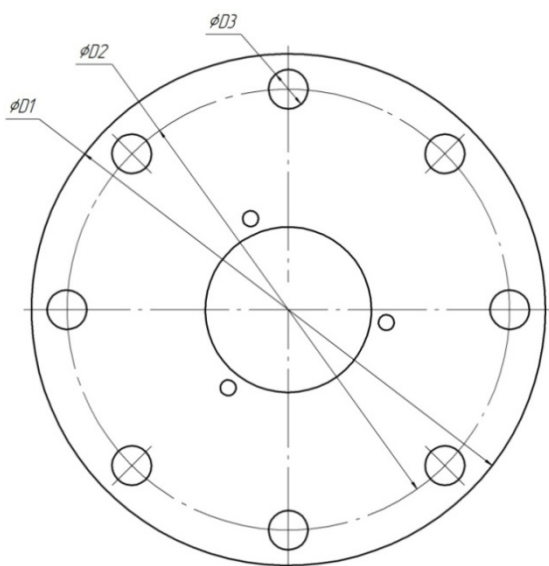

According to the order, ULM level transmitters can be fitted with various mounting (adapter) flanges pursuant to different standards (GOST, DIN, ANSI, etc.). Please make your request at the time of order placement.

Typical flanges supplied with ULM level transmitters correspond to GOST 12821-80, size DN150.

Flange	D1, mm	D2, mm	D3, mm
DN150, PN6	260	225	18
DN150, PN16	280	240	22